



# DA-10

*Vacuum Tube USB DAC*



Made in USA

## *Copyrights & Trademarks*

© Copyright Hagerman Audio Labs 2008. All rights reserved. No part of this document may be photocopied, reproduced, or translated to another language without the prior written consent.

## *Disclaimer*

The information contained in this document is subject to change without notice. Hagerman Audio Labs shall not be liable for errors contained herein or for consequential damages in connection with the furnishing, performance, or use of this material.

## *Warranty*

Hagerman Audio Labs warrants this product free of defects in materials and workmanship for a period of 10 years. If you discover a defect, Hagerman Audio Labs will, at its option, repair or replace the product at no charge to you provided you return it during the warranty period, transportation charges prepaid to Hagerman Audio Labs. This warranty does not apply if the product has been damaged by negligence, accident, abuse or misuse or misapplication, has been damaged because it has been improperly connected to other equipment or has been modified without the express written permission of Hagerman Audio Labs. This warranty is limited to the replacement or repair of this product and not to damage to equipment of other manufacturers. Any applicable implied warranties, including warranty of merchantability, are limited in duration to a period of the express warranty as provided herein beginning with the original date of purchase and no warranties, whether express or implied shall apply to the product thereafter. Under no circumstances shall Hagerman Audio Labs be liable for any loss, direct, indirect, incidental, special, or consequential damage arising out of or in connection with the use of this product.

### **Hagerman Audio Labs**

PO Box 26437

Honolulu, HI 96825

808-383-2704 (voice)

808-394-6076 (fax)

[www.haglabs.com](http://www.haglabs.com)

# Description

The DA-10 is a world-class analog-to-digital converter employing the latest technologies paired with vacuum tube amplification for a very clean and open musical reproduction. Input is via USB and optimized for 16 bit 44.1k redbook standard. Data is synchronously upsampled to 24-bits at 312.8kHz and re-timed using a super low-jitter flywheel type VCXO-based re-clocker circuit. The actual conversion is done using R2R 24-bit chips (the most expensive you can buy) with phase linear (perfect transient response) output filter / translators. A high-transconductance vacuum tube stage then provide the necessary gain and output buffering.

## *Package Contents*

- DA-10
- Power cord
- USB Cable

## *Specifications*

Item	Specification
Input	USB 1.1
Data Rate	44.1k samples per second, stereo 16 bit
Jitter	<10ps
Bandwidth (analog)	8Hz to 400kHz
Gain (analog)	33dB
Distortion	0.08%
Output Impedance	1.5k ohm
Output Voltage	1.8Vrms
SNR	
Size	10" x 10" x 4"
Weight	
Input Voltage	120Vac 35W
Tube Compliment	7788 (E810F) x 2

---

# Operation

The DA-10 connects between your computer (via USB cable) and linestage (or integrated amplifier). There are four front panel LEDs.

- LO:** Indicates low voltage and filament supplies
- HI:** Indicates high voltage tube plate supply
- CLK:** Indicates the reclocking circuit has locked
- DAT:** Indicates valid data received at the USB input

Connect the power cord to a 120Vac source. Turn on using the pushbutton power switch on the back panel. The DA-10 requires about 30 seconds warm-up to start playing, and another 30 minutes to sound its best, which is typical of high quality tube equipment. The **FILTER** switch on the back selects between slow and fast rolloff modes for the digital filter. Slow mode is more transient correct for better listening.

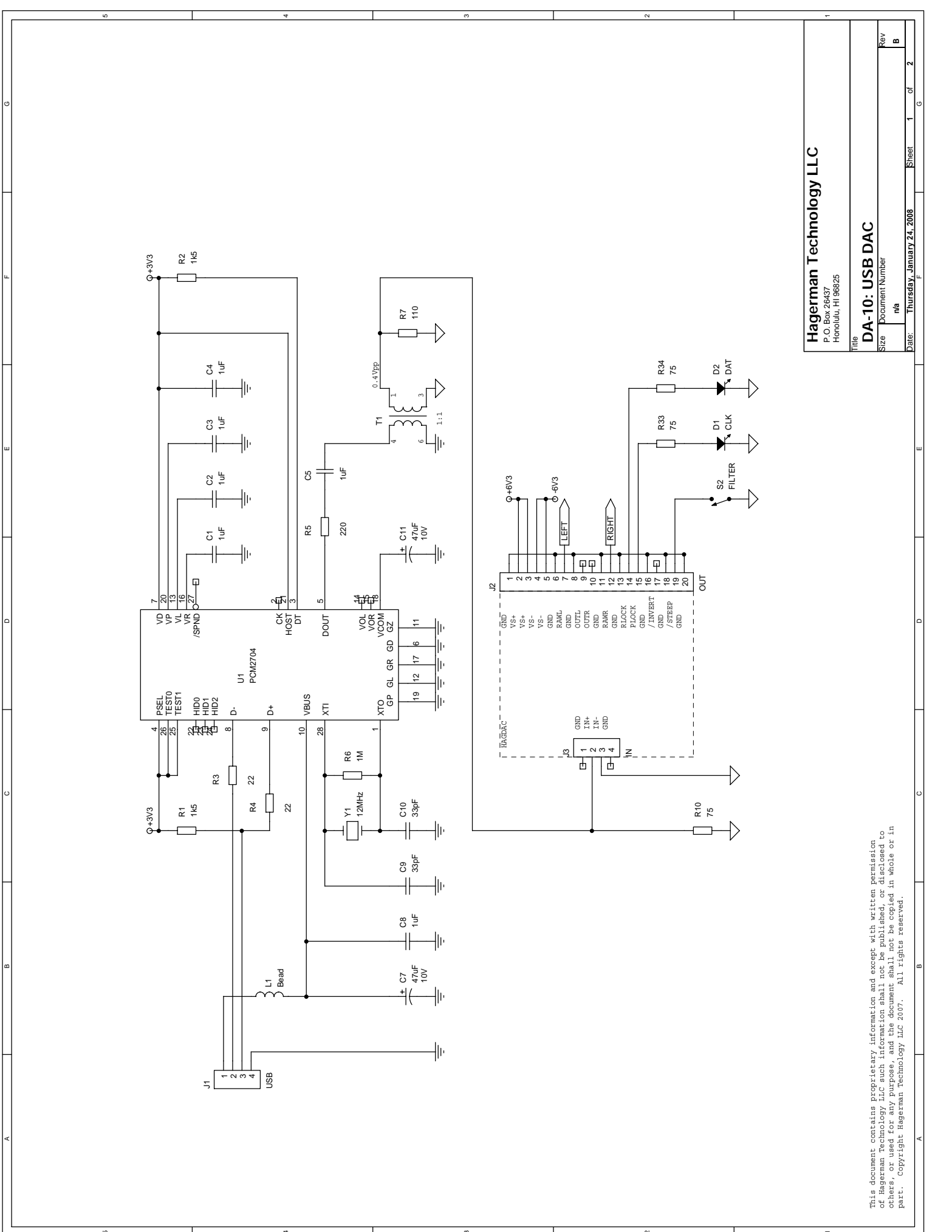

This document contains proprietary information and except with written permission of Hagerman Technology LLC such information shall not be published, or disclosed to others, or used for any purpose, and the document shall not be copied in whole or in part. Copyright Hagerman Technology LLC 2007. All rights reserved.

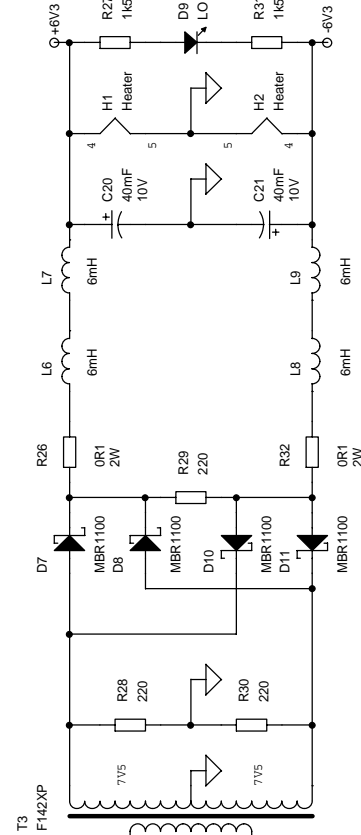
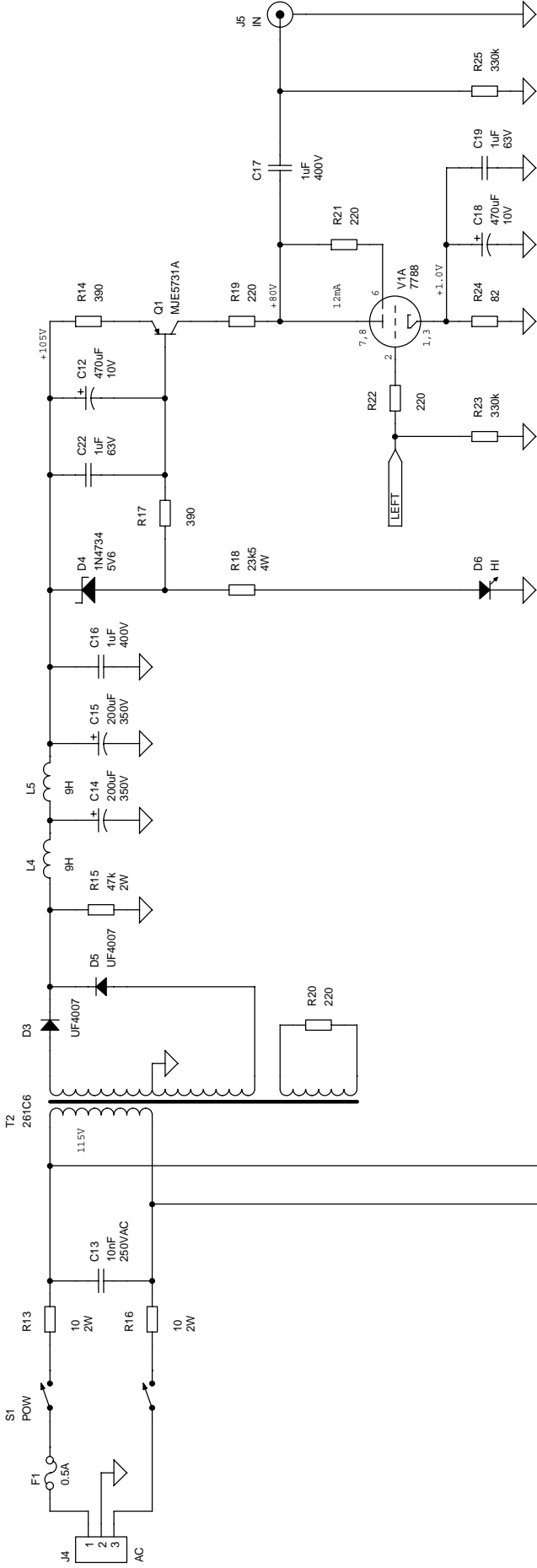

<b>Hagerman Technology LLC</b> P.O. Box 26467 Honolulu, HI 96825	
<b>DA-10: POWER</b> Document Number	
Title Size Date	n/a Thursday, January 24, 2008
Sheet 2 of 2	Rev B

This document contains proprietary information and except with written permission of Hagerman Technology LLC such information shall not be published, or disclosed to others, or used for any purpose, and the document shall not be copied in whole or in part. Copyright Hagerman Technology LLC 2007. All rights reserved.