

# INVENTION DISCLOSURE

10-NOV-2010

## TITLE

“Family of Intrinsically Absorptive Electronic Filters”

## INVENTORS

James G Hagerman, 1964 Nehoa Place, Honolulu, HI 96822  
Assigned to TeraSys Technologies LLC, 2800 Woodlawn Drive #198, Honolulu, HI 96822

## BACKGROUND

Typical electronic filters are reflective. That is, their  $S_{11}$  (return loss) is very high outside the passband, essentially reflecting all of the power back into the source. These filters are straightforward to design and build and have been the object of study and analysis since the dawn of radio. Huge texts have been written regarding their design (i.e. Zverev [3]).

There is another class of filters which is “absorptive”. Further terms used to describe this class are “reflectionless” and “invulnerable”, amongst others. These filters have a low return loss, where power in the stopband is mostly absorbed and burned off as heat instead of reflected back to the source. This is manifested as a 50 ohm (or whatever nominal) broadband impedance match on input and output ports.

The absorptive property can be of great benefit. For example, when an absorptive low-pass filter is inserted between a transmitter and antenna, several improvements are realized. In addition to the obvious reduction of transmitted harmonics and noise power in the stopband, the inherent impedance matching eliminates reflected power back into the transmitter, thus preventing VSWR damage and/or shutdown. Similarly, the antenna also sees a broadband impedance match, optimizing its intended specifications. In contrast, a reflective filter will cause mismatch resulting in RF performance errors.

## ABSTRACT

The invention described herein is a new set of electronic filter designs which are intrinsically absorptive. The family comprises low pass, high pass, band pass, and band stop types. They are an improvement upon prior art [2] in that they require fewer components and remove an undesirable transmission zero just outside of the passband.

In return for these performance gains, the degree of absorptiveness is somewhat compromised, but not to the point where it becomes an issue.

## **BRIEF DESCRIPTION OF DRAWINGS**

- 1) Cuthbert Invulnerable Filter Schematic
- 2) Morgan Reflectionless Filter Schematic
- 3) Five Section Morgan Reflectionless Low Pass
- 4) Hagerman Absorptive Low Pass Filter Schematic
- 5) Five Section Hagerman Absorptive Low Pass
- 6) Simulation Results of Figure 4
- 7) Hagerman Absorptive High Pass Filter Schematic
- 8) Five Section Hagerman Absorptive High Pass
- 9) Simulation Results of Figure 7
- 10) Hagerman Absorptive Band Pass Filter Schematic
- 11) Five Section Hagerman Absorptive Band Pass
- 12) Simulation Results of Figure 10
- 13) Hagerman Absorptive Band Stop Filter Schematic
- 14) Five Section Hagerman Absorptive Band Stop
- 15) Simulation Results of Figure 13
- 16) Comparison Of Morgan and Hagerman Low Pass Filters, Ideal
- 17) VSWR of Hagerman Low Pass
- 18) Comparison Of Morgan and Hagerman Low Pass Filters, Practical
- 19) Photo of Hagerman Absorptive Low Pass Breadboard
- 20) Measured Results of Figure 19
- 21) Photo of Hagerman Absorptive Band Pass Breadboard
- 22) Measured Results of Figure 21

## **PURPOSE**

The purpose of this invention is to improve upon the art of RF filtering by adding the absorptive property as an intrinsic feature. There are already other techniques to realize absorptiveness, such as references [4] and [5], but they are far more complex and expensive when reduced to practice.

## **DETAILED DESCRIPTION**

The concept of intrinsically absorptive filters has been a topic of academia for many years. The first known example is the bridged-T low-pass configuration (Figure 1) promoted by Cuthbert [1]. Mathematically it has a perfect S11 when assuming ideal components. Recently, Morgan [2] derived a more sophisticated version with improved S21 performance (Figure 2). These filters are impedance matched at both input and output making sections cascade very nicely for a higher order response.

The inventions described herein are improvements upon the Morgan. Circuit changes were made to eliminate the stopband notch and reduce the overall number of components. The compromise, however, is that perfect S11 is no longer obtained. It will be shown that such penalty is not so dramatic or harmful in practice.

Calculating component values for the Hagerman low-pass filter (Figure 4) is very straightforward. For a desired 3dB corner frequency, the formulas are:

$$C = \frac{1}{2 \cdot \pi \cdot f \cdot R}$$

$$L = \frac{R}{2 \cdot \pi \cdot f}$$

The minimum configuration is with the middle stage removed. In such a case a resemblance to the Morgan is apparent. The advantages of this invention become more pronounced when sections are cascaded. In practice, four or five stages are needed to produce a stopband of any useful consequence. Rarely is only 20dB of rejection needed. Simulation results of a five-section Hagerman low-pass filter set for a 100MHz corner frequency show desirable performance characteristics such as a steep rolloff, low pass band and stop band ripple, and better than -20dB return loss wideband (Figure 6).

The benefits of this invention are readily seen when compared to the equivalent five-section Morgan filter. The Hagerman is lower in complexity and component count (from 35 parts down to 21). Simulations show the Hagerman stop band is 10dB better with the notch removed (Figure 16). Although the return loss of the Morgan is ideally perfect, the Hagerman is quite acceptable, being typically better than 20dB, which equates to a very low VSWR (Figure 17). This is excellent performance under real-world conditions and in practical radio systems.

The low-pass filter prototype is easily translated into a high-pass type using standard methods (Figure 7). The performance is that of a perfect dual to the low-pass (Figure 7). Component values are calculated the same as for low-pass.

The band-pass and band-stop types however, are not translations of the low-pass. Doing so resulted in decent filters, but with S11 issues at the transitions. Modifications were made to the circuit, simplifying the wiring and reducing the number of components. These new filter designs (Figures 10, 13) offer excellent performance in their pass and stop bands while remaining intrinsically absorptive wideband (Figures 12, 15).

Component values are calculated using the following formulas:

$$C = \frac{1}{2 \cdot \pi \cdot (f_2 - f_1) \cdot R}$$

$$L = \frac{R}{2 \cdot \pi \cdot (f_2 - f_1)}$$

$$C_x = \frac{(f_2 - f_1)}{2 \cdot \pi \cdot f_2 \cdot f_1 \cdot R}$$

$$L_x = \frac{(f_2 - f_1) \cdot R}{2 \cdot \pi \cdot f_2 \cdot f_1}$$

Interestingly, at 100% bandwidth (golden ratio),  $L = L_x$  and  $C = C_x$ , reducing the number of different parts. Similarly, the 50% bandwidth calculation offers a 2:1 component ratio, which is simple to implement in practice.

A prototype low-pass filter was constructed on a circuit board with a design corner frequency of about 220MHz (Figure 19). It was a five-stage Hagerman design. Components and layout can accommodate 100 watts of transmitter power in the pass band and about 10 watts in the stop band. The measured versus simulated responses prove the viability of this invention (Figure 20).

Similarly, a prototype band pass filter was constructed with corner frequencies of approximately 100MHz and 200MHz (Figure 21). The measured data versus simulated response matches quite well (Figure 22).

## **ADVANTAGES**

The advantages of an absorptive filter have been sufficiently described by prior art. Further advantages of this invention are manifested in its reduced complexity, lower number of parts, lower cost, and improved stopband performance. In a competitive marketplace, this is significant.

## **PRIOR ART**

Previous implementations for an intrinsically absorptive filter targeted perfect S11. Although a noble cause, this is not always practical. The frequency response of the Morgan Filter is less than desirable with a notch just outside of the passband followed by a hump at higher frequencies. Additionally, when practical components are used (non-ideal), the quality of S11 is greatly compromised, as shown in a simulated comparison between a five-section Morgan (pink) and Hagerman (red) low-pass filters

(Figure 18). The Hagerman also uses roughly 35% fewer parts than the Morgan and yet has a 10dB advantage in the stopband for S21.

Other known techniques such as the Miyashiro [4] and Do [5] provide an absorptive S11, but at far greater cost and complexity and is based on entirely different techniques.

## REFERENCES

1. Thomas R Cuthbert Jr, "Broadband Direct-Coupled and Matching RF Networks", 1999.
2. Matthew A Morgan, "Synthesis of a New Class of Reflectionless Filter Prototypes", 2009.
3. Anatol I Zverev, "Handbook of Filter Synthesis", 1969.
4. Kevin Miyashiro, "Electronically Tunable Absorptive Low-Loss Notch Filter", US Patent Application #20090289744, 2009.
5. Ky H Do, "Method for an Ultra-Wide Pass Band Absorptive Band Reject Filter", US Provision Patent Application #, 2009.

**PRIOR ART**

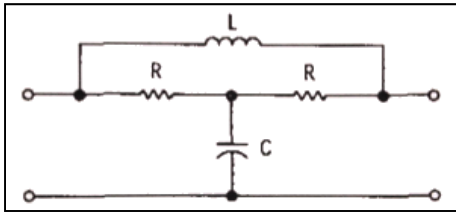

**Figure 1 – Cuthbert Invulnerable Filter Schematic**

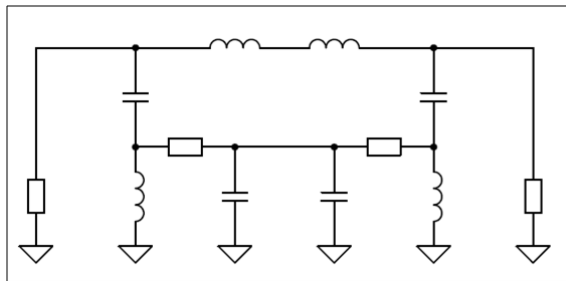

**Figure 2 – Morgan Reflectionless Low Pass Filter Schematic**

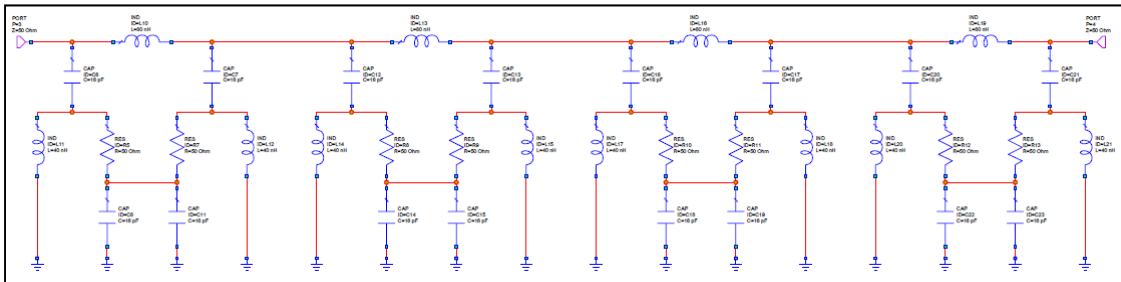

**Figure 3 - Five Section Morgan Reflectionless Low Pass**

# LOW PASS

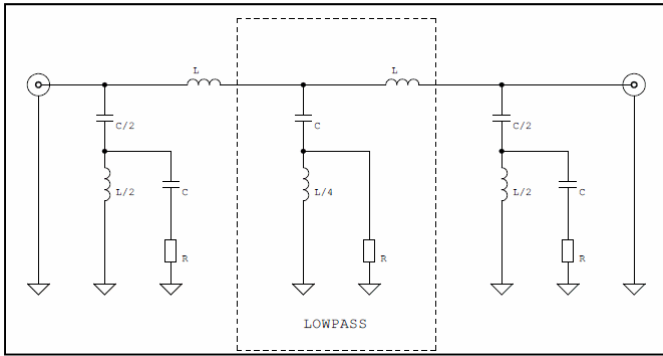

Figure 4 – Hagerman Absorptive Low Pass Filter Schematic

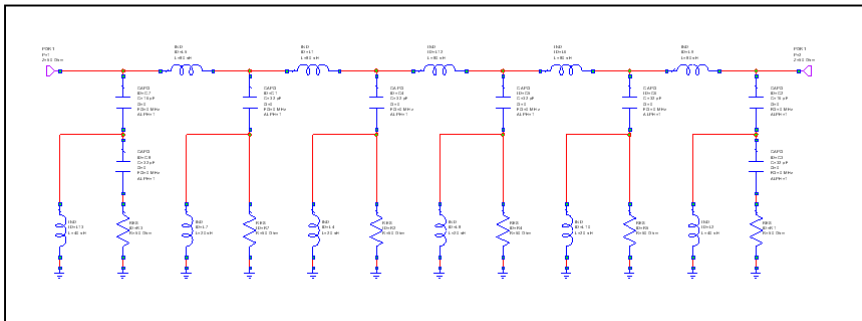

Figure 5 – Five Section Hagerman Absorptive Low Pass

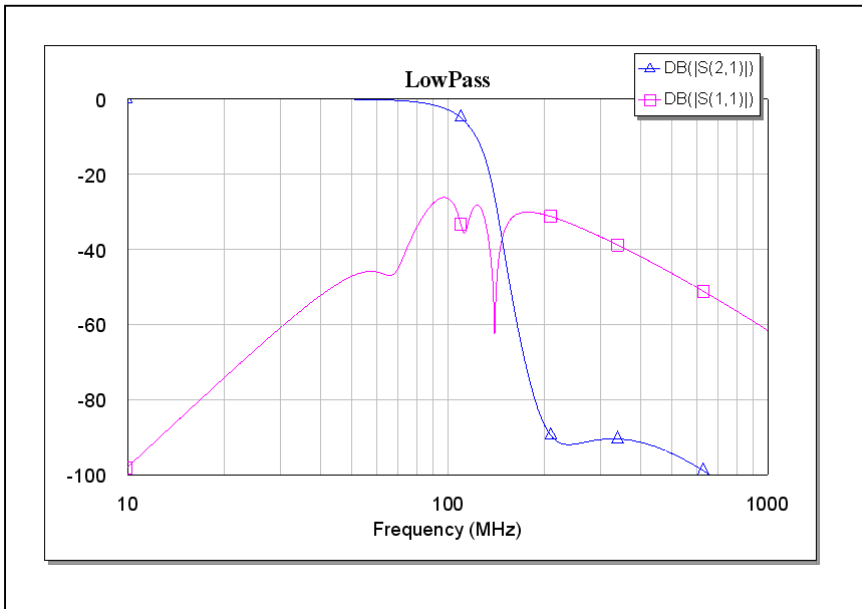

Figure 6 – Simulation Results of Figure 4

# HIGH PASS

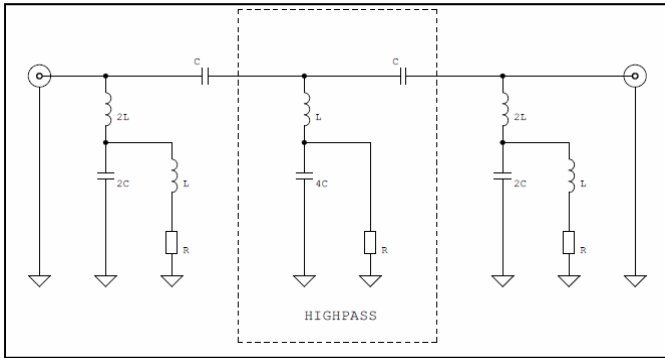

Figure 7 – Hagerman Absorptive High Pass Filter Schematic

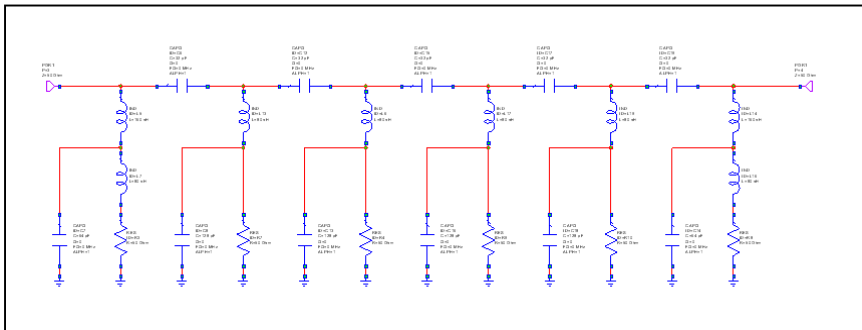

Figure 8 – Five Section Hagerman Absorptive High Pass

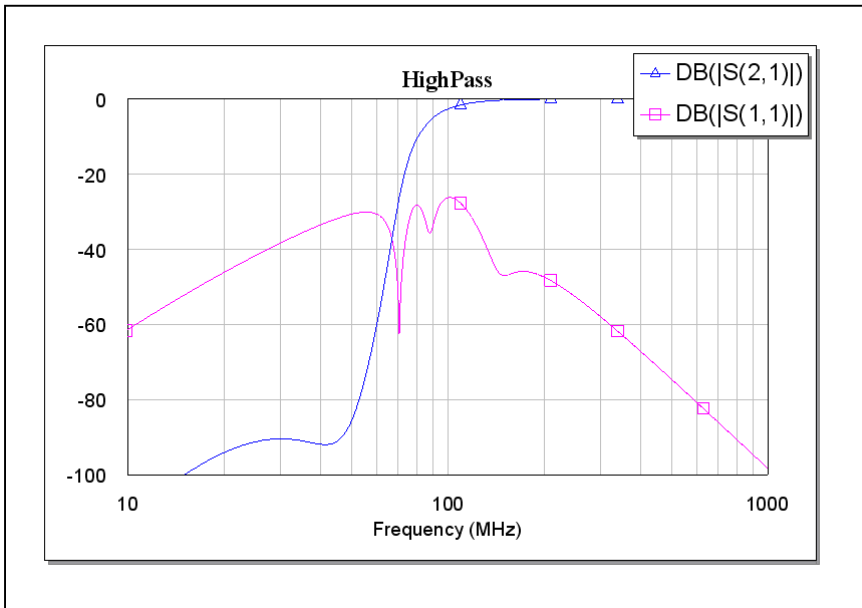

Figure 9 – Simulation Results of Figure 7



# BAND PASS

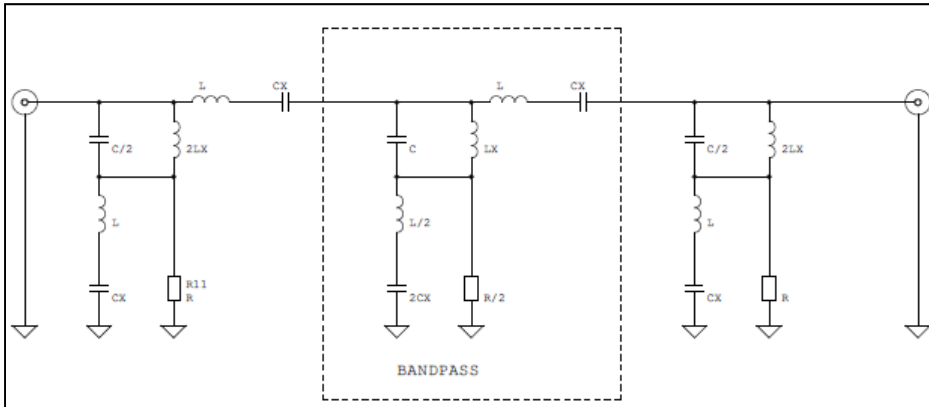

Figure 10 – Hagerman Absorptive Band Pass Filter Schematic

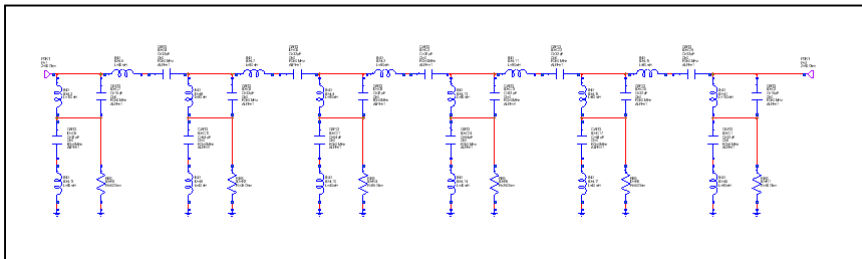

Figure 11 – Five Section Hagerman Absorptive Band Pass

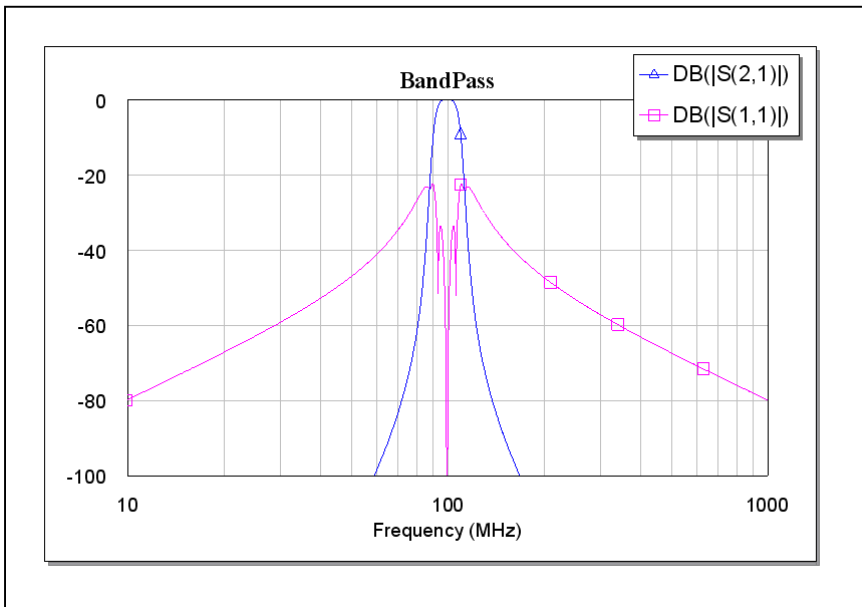

Figure 12 – Simulation Results of Figure 10

# BAND STOP

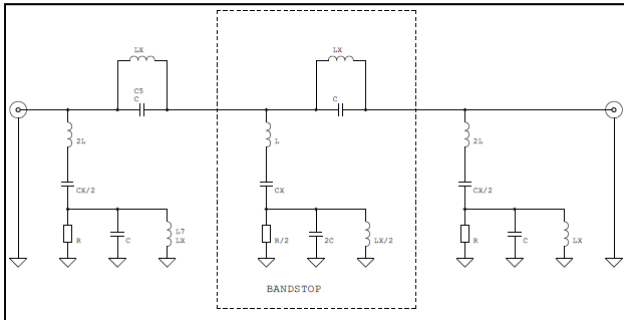

Figure 13 – Hagerman Absorptive Band Stop Filter Schematic

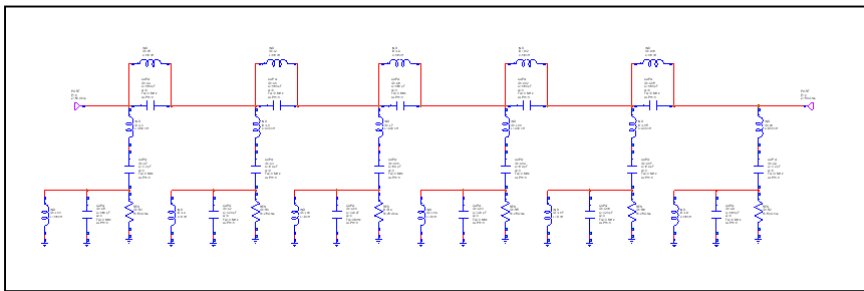

Figure 14 – Five Section Hagerman Absorptive Band Stop

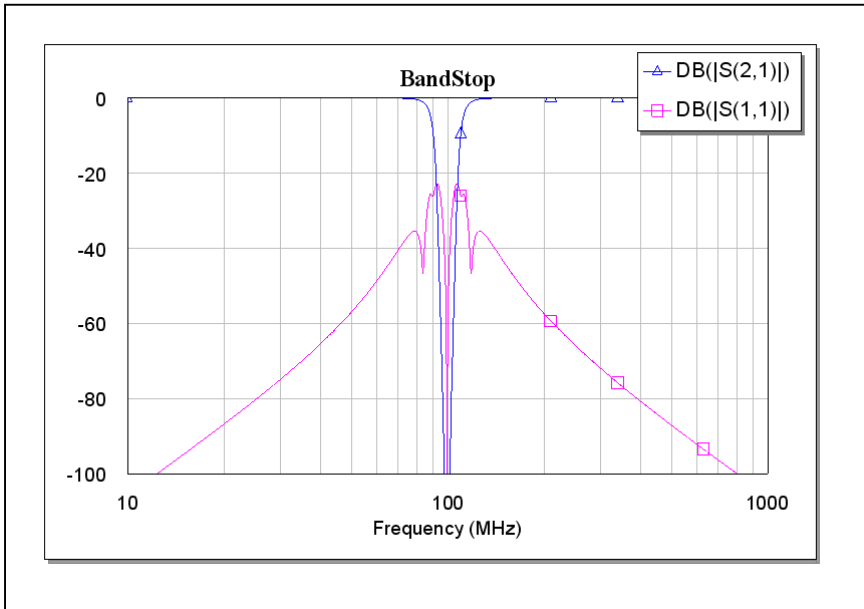

Figure 15 – Simulation Results of Figure 13

## SIMULATIONS

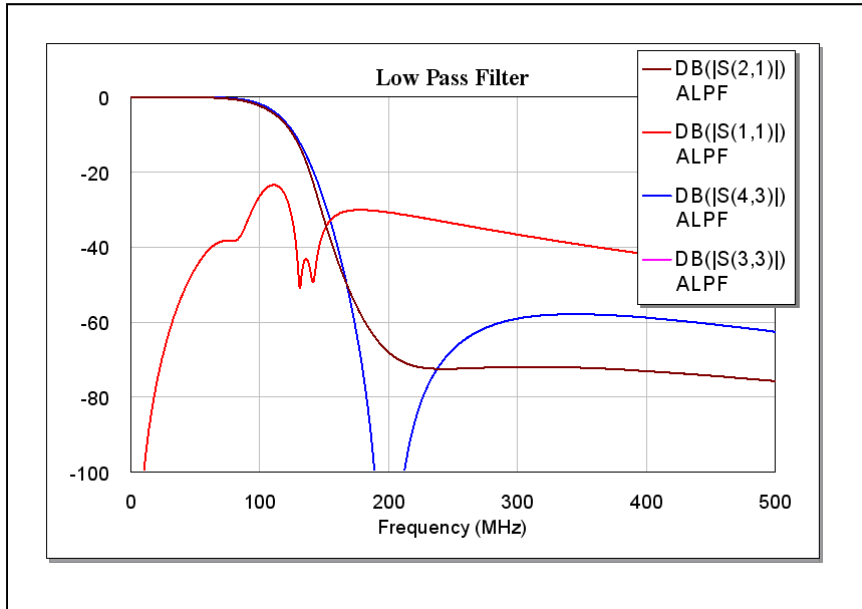

Figure 16 – Comparison of Morgan and Hagerman Low Pass Filters, Ideal

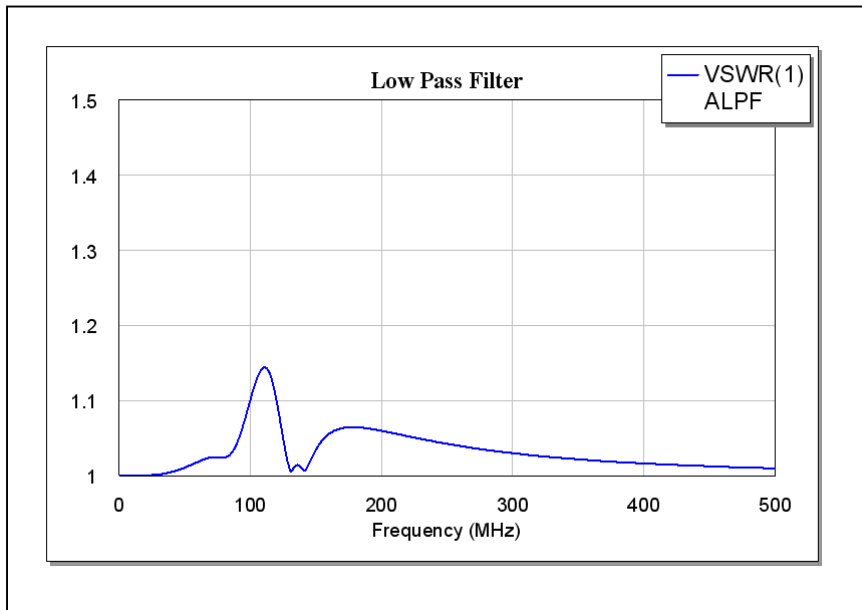

Figure 17 – VSWR of Hagerman Low Pass

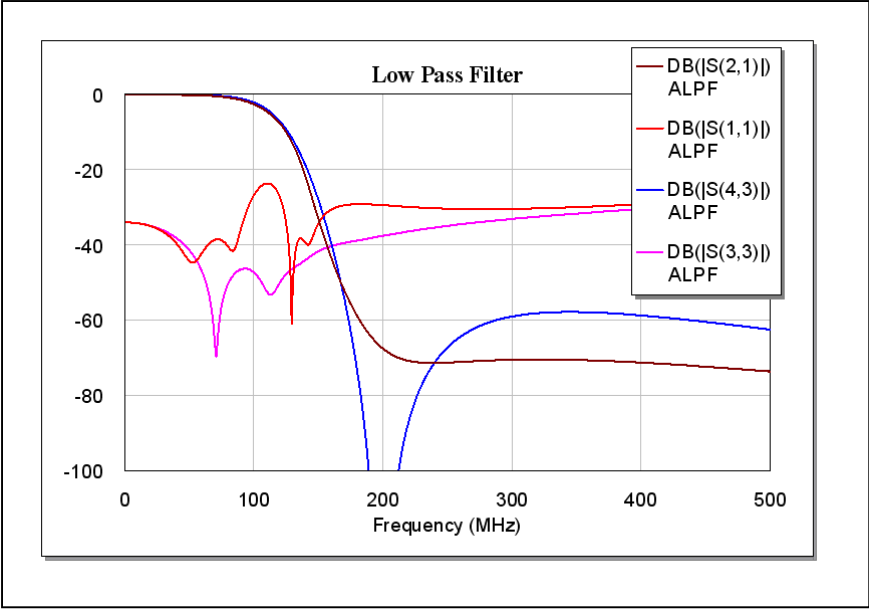

Figure 18 – Comparison of Morgan and Hagerman Low Pass Filters, Practical

## REDUCTION TO PRACTICE

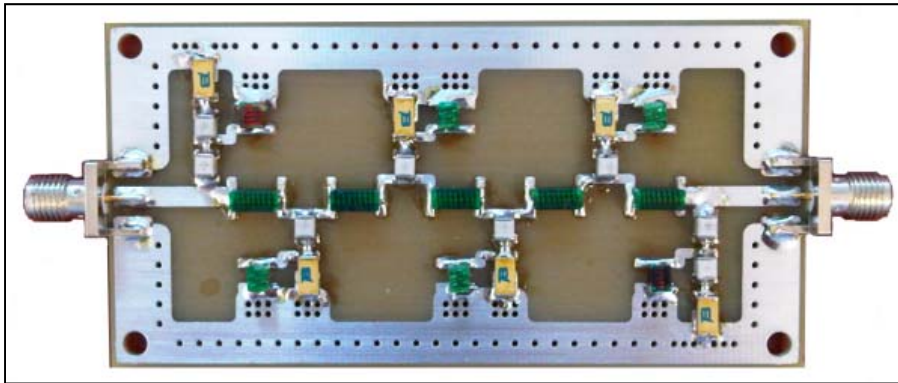

Figure 19 – Photo of Hagerman Absorptive Low Pass Breadboard

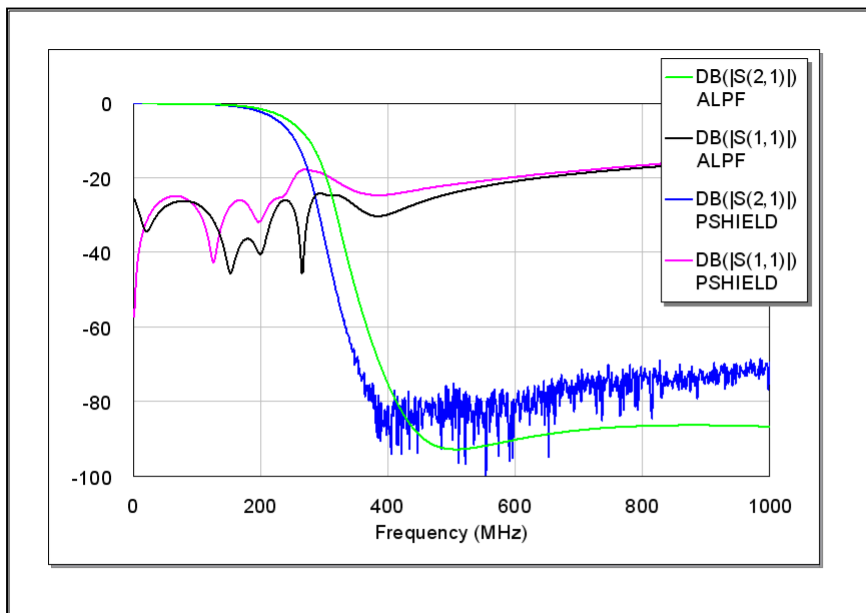

Figure 20 – Measured Results of Figure 19

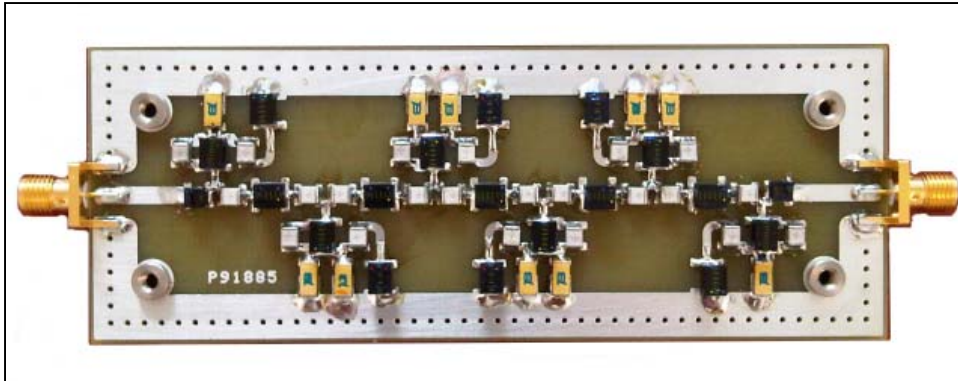

Figure 21 – Photo of Hagerman Absorptive Band Pass Breadboard

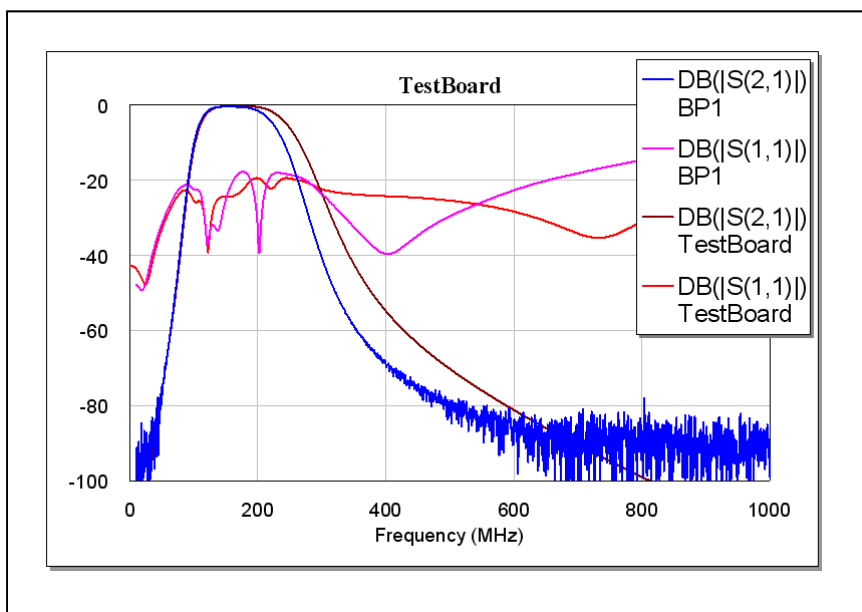

Figure 22 – Measured Results of Figure 21