



FRYDADDY

Cable Burn-in Generator



Made in USA

Copyrights & Trademarks

© Copyright Hagerman Audio Labs 2008. All rights reserved. No part of this document may be photocopied, reproduced, or translated to another language without the prior written consent. FryKleaner™ is a trademark of Hagerman Technology LLC.

Disclaimer

The information contained in this document is subject to change without notice. Hagerman Audio Labs shall not be liable for errors contained herein or for consequential damages in connection with the furnishing, performance, or use of this material.

Warranty

Hagerman Audio Labs warrants this product free of defects in materials and workmanship for a period of 10 years. If you discover a defect, Hagerman Audio Labs will, at its option, repair or replace the product at no charge to you provided you return it during the warranty period, transportation charges prepaid to Hagerman Audio Labs. This warranty does not apply if the product has been damaged by negligence, accident, abuse or misuse or misapplication, has been damaged because it has been improperly connected to other equipment or has been modified without the express written permission of Hagerman Audio Labs. This warranty is limited to the replacement or repair of this product and not to damage to equipment of other manufacturers. Any applicable implied warranties, including warranty of merchantability, are limited in duration to a period of the express warranty as provided herein beginning with the original date of purchase and no warranties, whether express or implied shall apply to the product thereafter. Under no circumstances shall Hagerman Audio Labs be liable for any loss, direct, indirect, incidental, special, or consequential damage arising out of or in connection with the use of this product.

Hagerman Audio Labs

PO Box 61911

Honolulu, HI 96839

808-383-2704

www.haglabs.com

Description

The FryDaddy is a high-powered cable burn-in generator and conditioner that can also be used for phono and line stages. The sophisticated electronic waveform – a combination of wideband noise and variable frequency amplitude modulation – was developed to provide a maximum combination of both low and high frequency content without being repetitious in any way. Burn-in operates on magnetic and electrical properties of conductors and insulators. FryDaddy is part of the FryKleaner™ series of professional cable burn-in generators.

Package Contents

- FryDaddy
- Power cord

Specifications

Item	Specification
Output Voltage	20Vpp (CABLE) 1Vrms (LINE) 10mVrms (MM) 1mVrms (MC)
Output Impedance	150 ohm
Signal Bandwidth	10Hz to 100kHz
AC Voltage	120Vac 60Hz

Operation

The FryDaddy's AMPLITUDE knob sets the manner of operation. MC selects an output level suitable for driving moving coil phono stage inputs (-60dB), MM for moving magnet phono stages (-40dB), LINE for sensitive cables and amplifiers (0dB), and CABLE for directly burning-in wire products.

There are two modes of cable burn-in, voltage and current. Both are required for maximum effectiveness. Experience has determined that good results are obtained with 24 hours of voltage mode followed by 48 hours of current mode.

Voltage Mode

In voltage mode the cable dielectric is excited by electric fields. Connect cables to the upper sets of connectors and binding posts (red). Leave the far end of the cable open-circuited.

Current Mode

In current mode, the cable must be short-circuited. This is done by connecting the open end of the cable to the set of connectors and binding posts on the bottom (black). Current mode is not applicable when using the FryBaby to burn in amplification.

Power Cords

You can burn-in power cords by plugging into the outlet. For current mode, you can short circuit the far end of the cord or plug it into equipment.

Monitor

The output signal can be monitored or used for other inputs. The MONITOR output is a BNC connector and is not current limited.

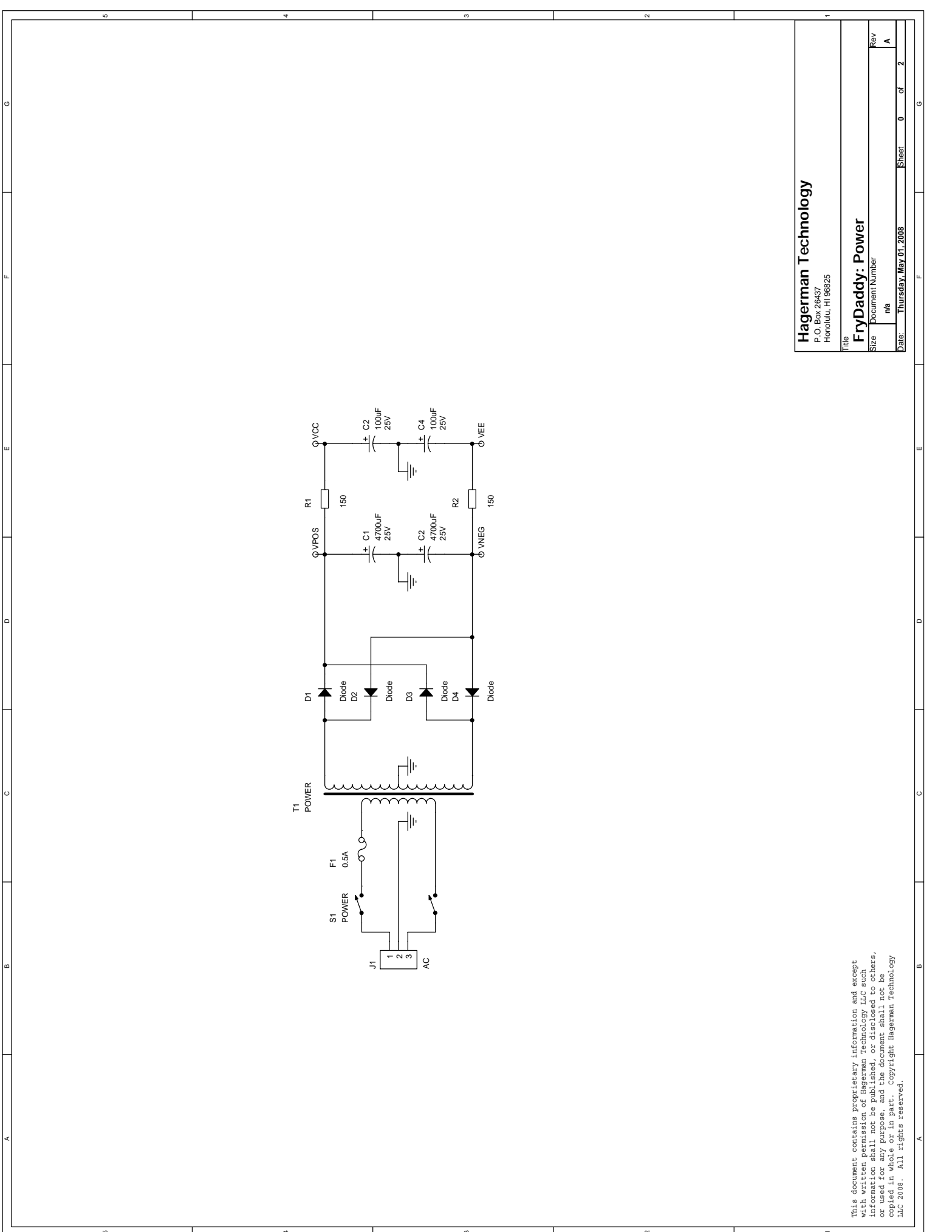

Hagerman Technology
P.O. Box 26437
Honolulu, HI 96825

FryDaddy: Power
Document Number
na

Date: Thursday, May 01, 2008
Sheet 0 of 2

This document contains proprietary information and except with written permission of Hagerman Technology LLC such information shall not be published, or disclosed to others, or used for any purpose, and the document shall not be copied in whole or in part. Copyright Hagerman Technology LLC 2008. All rights reserved.

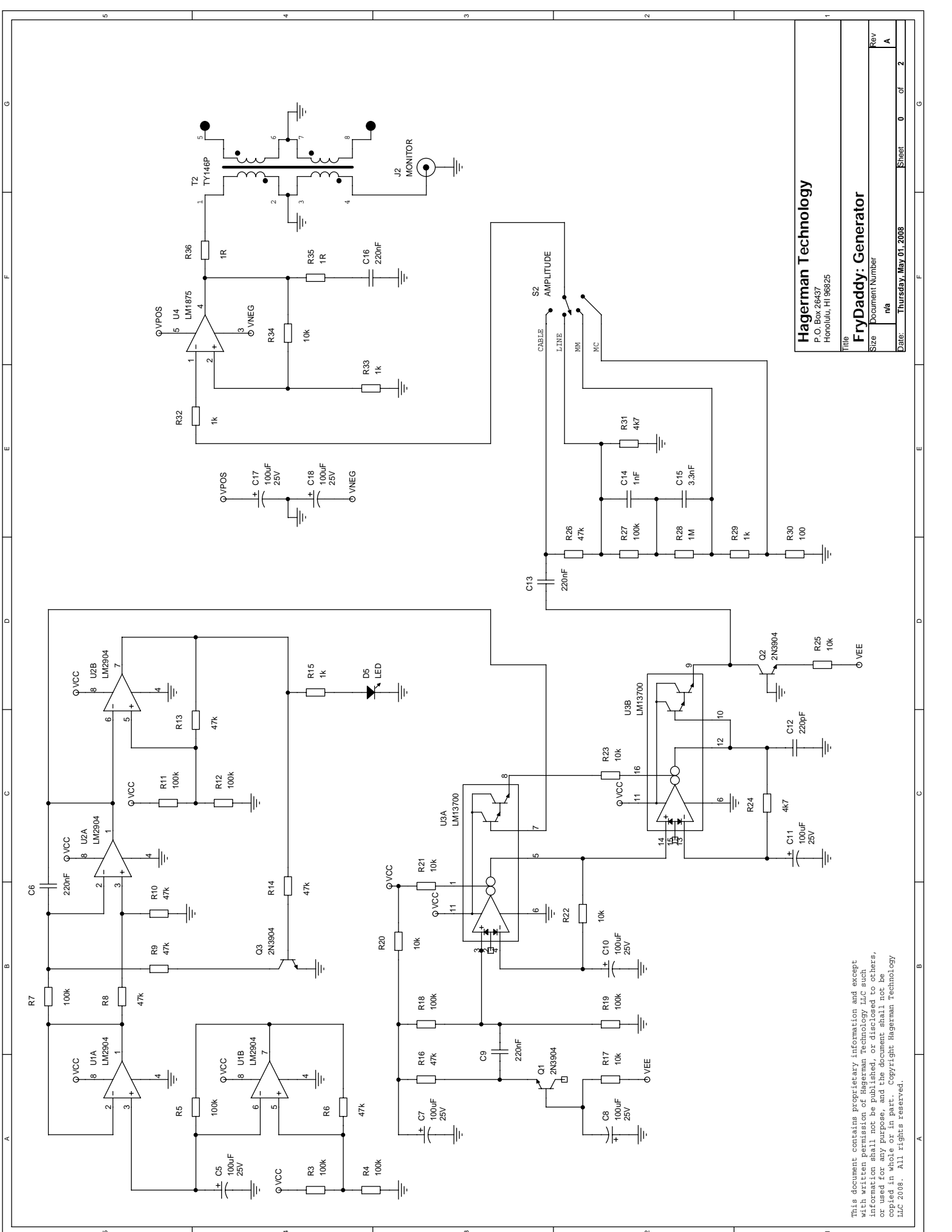

Hagerman Technology
P.O. Box 26437
Honolulu, HI 96825

Title: **FryDaddy: Generator**
Size: Document Number
Rev: n/a
Date: Thursday, May 01, 2008

This document contains proprietary information and except with written permission of Hagerman Technology LLC such information shall not be published, or disclosed to others, or used for any purpose, and the document shall not be copied in whole or in part. Copyright Hagerman Technology LLC 2008. All rights reserved.