



FRYCORDER

Power Cord Burn-in Generator



Made in USA

Copyrights & Trademarks

© Copyright Hagerman Audio Labs 2012. All rights reserved. No part of this document may be photocopied, reproduced, or translated to another language without the prior written consent. FryKleaner™ and FryCorder™ are trademarks of Hagerman Technology LLC.

Disclaimer

The information contained in this document is subject to change without notice. Hagerman Audio Labs shall not be liable for errors contained herein or for consequential damages in connection with the furnishing, performance, or use of this material.

Warranty

Hagerman Audio Labs warrants this product free of defects in materials and workmanship for a period of 10 years. If you discover a defect, Hagerman Audio Labs will, at its option, repair or replace the product at no charge to you provided you return it during the warranty period, transportation charges prepaid to Hagerman Audio Labs. This warranty does not apply if the product has been damaged by negligence, accident, abuse or misuse or misapplication, has been damaged because it has been improperly connected to other equipment or has been modified without the express written permission of Hagerman Audio Labs. This warranty is limited to the replacement or repair of this product and not to damage to equipment of other manufacturers. Any applicable implied warranties, including warranty of merchantability, are limited in duration to a period of the express warranty as provided herein beginning with the original date of purchase and no warranties, whether express or implied shall apply to the product thereafter. Under no circumstances shall Hagerman Audio Labs be liable for any loss, direct, indirect, incidental, special, or consequential damage arising out of or in connection with the use of this product.

Hagerman Audio Labs

PO Box 61911

Honolulu, HI 96839

808-383-2704

www.haglabs.com

Description

The FryCorder is a burn-in signal generator designed specifically for audio equipment power cords and room wiring. Just plug the unit into the wall and it immediately sends the sophisticated burn-in signal (a combination of wideband noise and random amplitude modulation) into the wiring. FryCorder is part of the FryKleaner™ series of professional cable burn-in generators.

Specifications

Item	Specification
Output Power	1W peak (both Line and Neutral)
Signal Bandwidth	1kHz to 100kHz
AC Voltage	120Vac 60Hz or 240Vac 50Hz

Operation

To burn-in a power cord, just plug into the FryCorder and then into a power outlet. It is that simple. The FryCorder circuit immediately starts up and sends the signal into the power cord and house wiring. A red LED inside the case will blink indicating proper operation. The burn-in signal travels through the power wiring until it reaches the utility transformer, which does not have enough bandwidth to pass the signal. Depending on the loading and impedance of the AC wiring, the signal will be a combination of currents at the lower frequencies and voltages at the higher. This method of power delivery is most effective for the break-in of both conductors and insulators, resulting in a better and quieter delivery of power to your audio equipment.

Duration

Empirical testing has led to the conclusion that most wiring achieves break-in after two or three days of continuous burn. Silver conductors seem to take twice as long as copper.

Troubleshooting

In case of trouble, please contact jim@haglabs.com.

Problem	Solution
LED does not light up.	Attach power cord, plug into AC outlet.

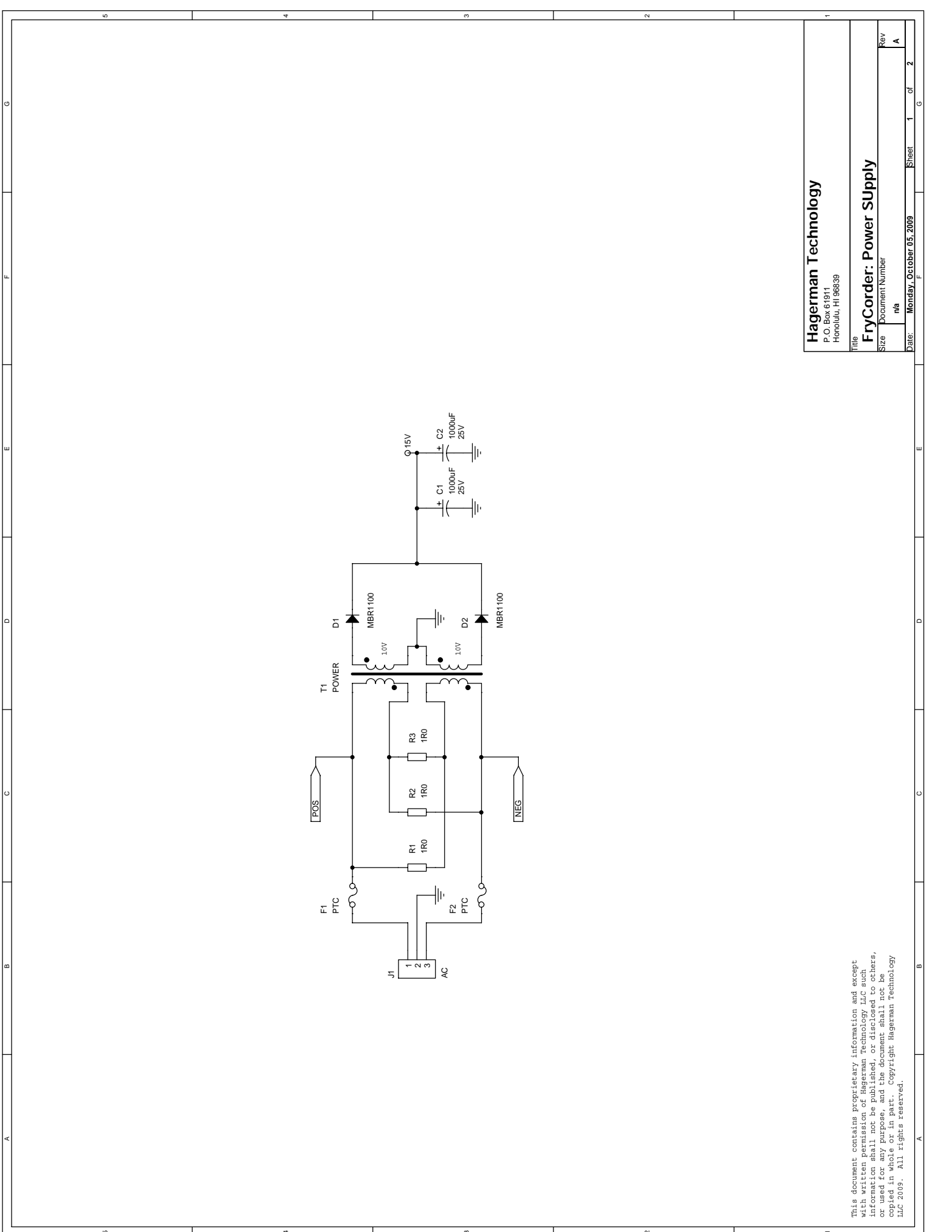

Hagerman Technology
P.O. Box 61911
Honolulu, HI 96839

FryCorder: Power Supply

Title			
Size	Document Number	Rev	
	na	A	
Date:	Monday, October 05, 2009	Sheet	1 of 2

This document contains proprietary information and except with written permission of Hagerman Technology LLC such information shall not be published, or disclosed to others, or used for any purpose, and the document shall not be copied in whole or in part. Copyright Hagerman Technology LLC 2009. All rights reserved.

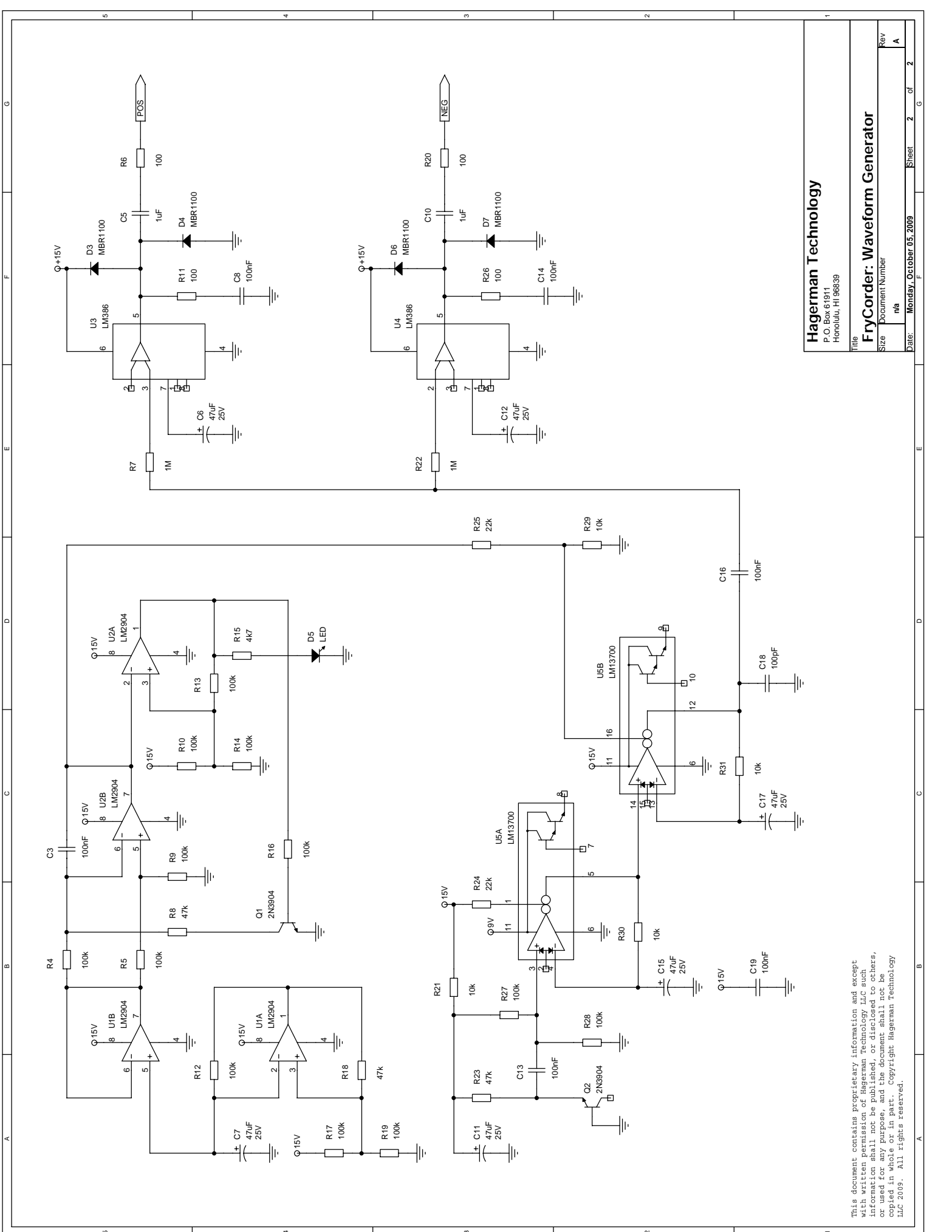

Hagerman Technology
P.O. Box 61911
Honolulu, HI 96839

FryCorder: Waveform Generator
Size Document Number
n/a

Date: Monday, October 05, 2009
Sheet 2 of 2

This document contains proprietary information and except with written permission of Hagerman Technology LLC such information shall not be published, or disclosed to others, or used for any purpose, and the document shall not be copied in whole or in part. Copyright Hagerman Technology LLC 2009. All rights reserved.