



FLUGELHORN

Variable EQ Phonostage



Made in USA

Copyrights & Trademarks

© Copyright Hagerman Audio Labs 2008. All rights reserved. No part of this document may be photocopied, reproduced, or translated to another language without the prior written consent.

Disclaimer

The information contained in this document is subject to change without notice. Hagerman Audio Labs shall not be liable for errors contained herein or for consequential damages in connection with the furnishing, performance, or use of this material.

Warranty

Hagerman Audio Labs warrants this product free of defects in materials and workmanship for a period of 10 years (90 days on tubes). If you discover a defect, Hagerman Audio Labs will, at its option, repair or replace the product at no charge to you provided you return it during the warranty period, transportation charges prepaid to Hagerman Audio Labs. This warranty does not apply if the product has been damaged by negligence, accident, abuse or misuse or misapplication, has been damaged because it has been improperly connected to other equipment or has been modified without the express written permission of Hagerman Audio Labs. This warranty is limited to the replacement or repair of this product and not to damage to equipment of other manufacturers. Any applicable implied warranties, including warranty of merchantability, are limited in duration to a period of the express warranty as provided herein beginning with the original date of purchase and no warranties, whether express or implied shall apply to the product thereafter. Under no circumstances shall Hagerman Audio Labs be liable for any loss, direct, indirect, incidental, special, or consequential damage arising out of or in connection with the use of this product.

Hagerman Audio Labs

PO Box 26437

Honolulu, HI 96825

808-383-2704 (voice)

808-394-6076 (fax)

www.haglabs.com

Description

The Flugelhorn is a phonostage offering variable equalization, loading, gain, and polarity. This flexibility makes it unique in that it can operate with any MM or MC cartridge, and play back any record, whether modern stereo, or mono 33s and 78s of any known equalization. The circuitry is fully differential using discrete matched JFETs to implement gain and buffer stages without feedback, giving a fatigue-free sonic presentation with excellent timing and clarity.

Package Contents

- Flugelhorn
- Power cord

Specifications

Item	Specification
Gain	45, 50, 55, 60, 65, 70 dB
Input Impedance	50, 100, 47k (mono and stereo)
Output Impedance	300 ohm
RIAA Response	+/-0.5dB from 25Hz to 25kHz
Bandwidth	15Hz to 350kHz
Distortion	0.05% @1kHz
Noise	66dB ref 500uV A-weighted
Turnover	150, 200, 300, 400, 500, 700 Hz
Cut	0, 5, 10.5, 12, 13.7, 16 dB @10kHz
Size	10" x 10" x 4" (not including tubes)
Power	120Vac, 5W

Operation

Connect the ground lead from your turntable to the ground lug on the rear panel. Connect phono leads to the input jacks, output jacks to your linestage. Set front panel switches to the appropriate setting. RIAA equalization (stereo) is indicated by the dots. The "0" position on the PHASE switch is mute. SENSITIVITY should be set to match your cartridge's output level. LOADING is adjusted to taste (use 47k for MM).

Connect the power cord to a 120Vac source. Turn on using the power switch on the back panel. The Flugelhorn will operate immediately and does not require a lengthy warmup period.

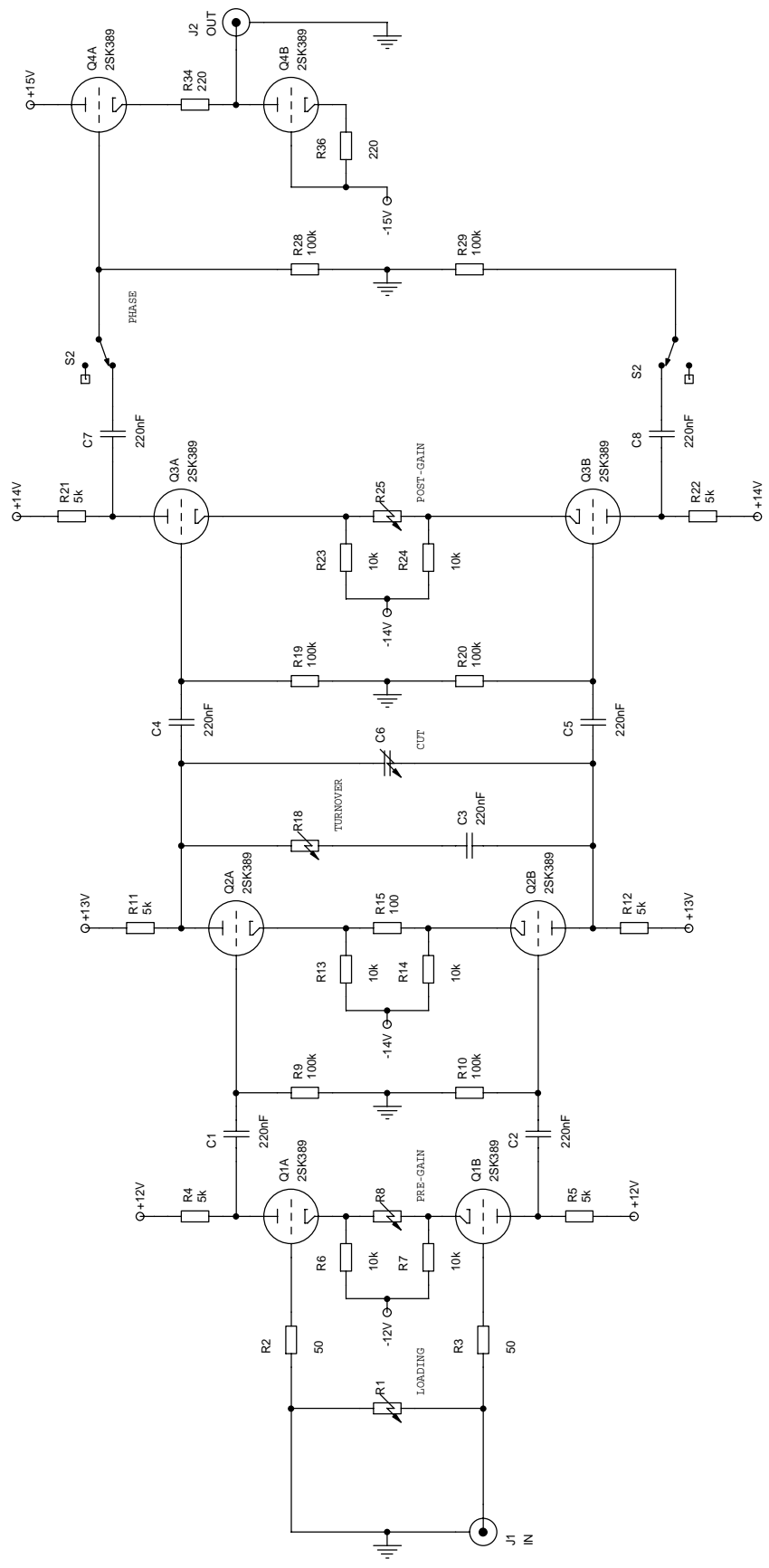

RL	R8	R18	C6	R25
49F9	22k	4K53	0n	68k
100	150	3K65	22n	499
221	439	2K43	47n	332
499	1K00	1K82	62n	221
4869	2K51	1K43	50n	150
49K9	4K29	1K00	100n	100

Hagerman Technology LLC
 P.O. Box 26467
 Honolulu, HI 96825

Title: **FLUGELHORN: Phono**
 Size: Document Number
 n/a
 Date: Thursday, April 24, 2008

This document contains proprietary information and except with written permission of Hagerman Technology LLC such information shall not be published, or disclosed to others, or used for any purpose, and the document shall not be copied in whole or in part. Copyright Hagerman Technology LLC 2008. All rights reserved.

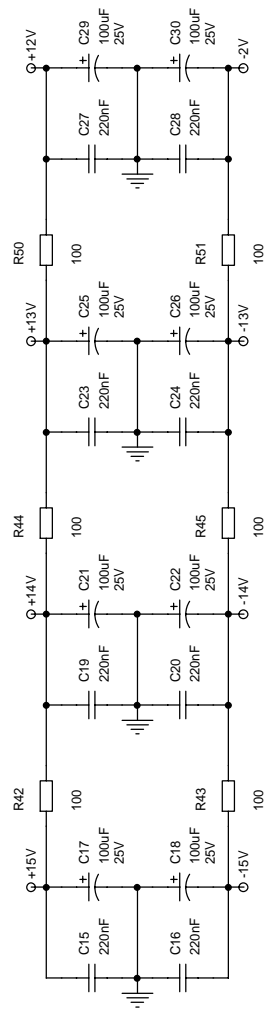
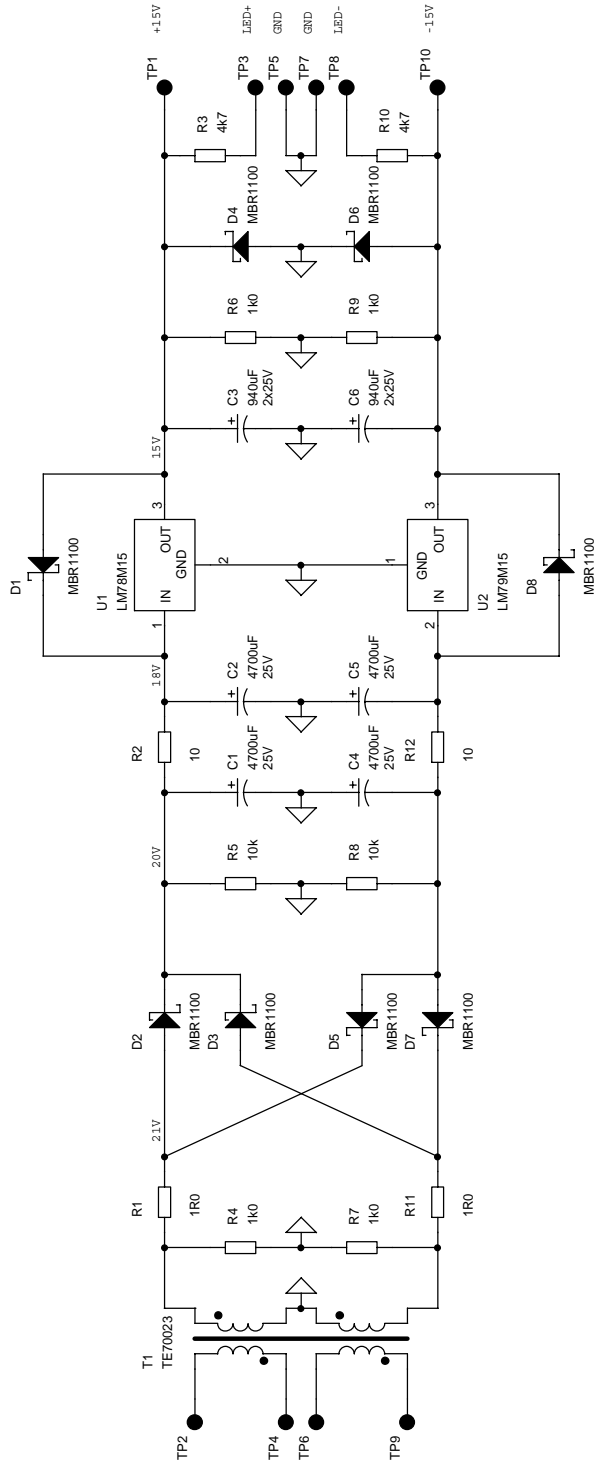

Hagerman Technology
 P.O. Box 26467
 Honolulu, HI 96825

Title: **FLUGELHORN: Power**
 Size: Document Number
 n/a

Date: Thursday, April 24, 2008
 Sheet 0 of 1

This document contains proprietary information and except with written permission of Hagerman Technology LLC such information shall not be published, or disclosed to others, or used for any purpose, and the document shall not be copied in whole or in part. Copyright Hagerman Technology LLC 2008. All rights reserved.